

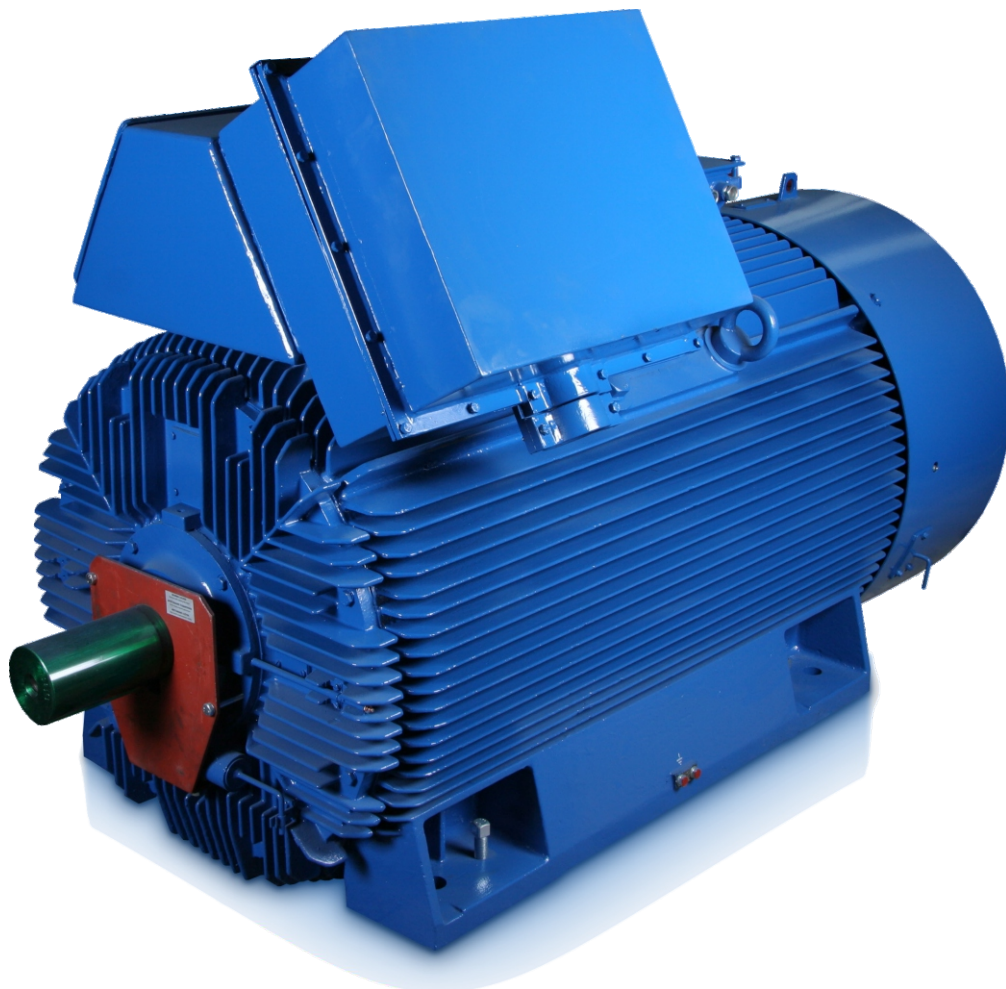

Product Catalogue

Squirrel Cage Motors

High Voltage



## Certificates

**Cantoni Motor SA**  
ISO 9001  
Since September 30, 1999

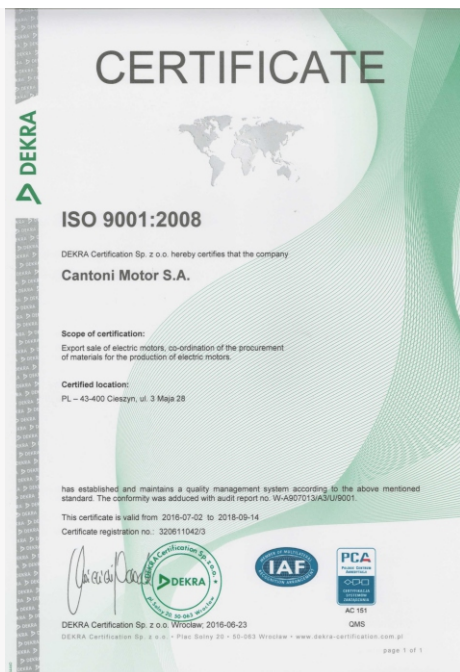

**Besel SA**  
ISO 9001  
Since July 21, 1995

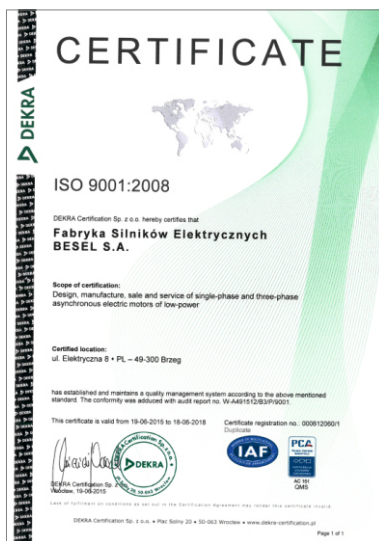

**Celma Indukta SA**  
ISO 9001  
Since April 1, 1993



**ISO 14001**  
Since November 15, 1999

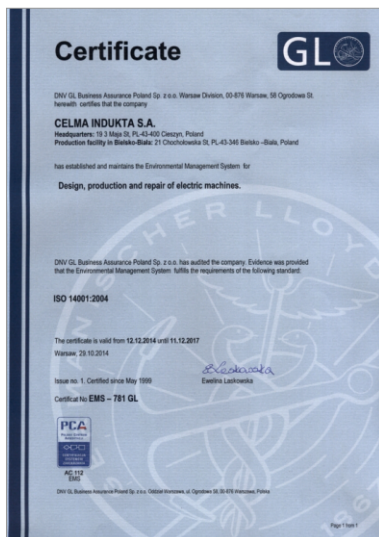

**Emit SA**  
ISO 9001:2008  
ISO 14001:2004  
Since January 23, 2012





since 1948



Product range beginning from 0,04kW up to 5000kW

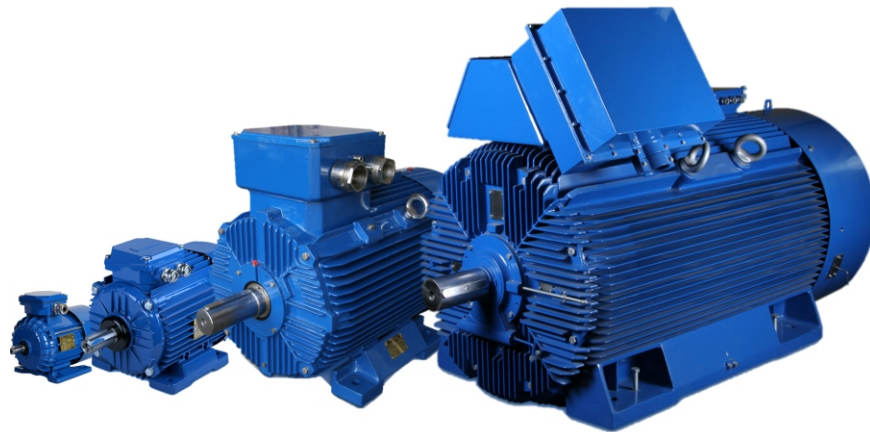

„FFD part of Cantoni Goup” in numbers

- ~ 1900 employees
- Annual production ~ 1.000.000 motors
- Covered area ~ 120.000 m<sup>2</sup>

**OUR SOLUTION FOR YOUR POWER!**

# Contents

**General information**

**pages 5-6**

- Introduction to High Voltage motors
- Discription of the catalogue version
- Discription of the customised version
- Tolerances
- Bearings

**Technical data**

- Scf motors **page 7**
- Sf motors **page 8**
- SVf motors **page 9**
- Sf(w) motors **page 10**
- Sf motors **page 11**
- Sh motors **pages 12-13**

**Dimensional drawings**

**pages 14-19**

**Productio program**

**pages 20-21**

**Notice**

**pages 22-23**



This catalogue contains description and basic technical data of three-phase squirrel cage HV-motors, open drip-proof IP23 and totally enclosed IP54 and IP55. Basic production range of motors contains the following :

	Output range	Degree of protection	Cooling system	Mounting arrangement
■ SCf 315-450	200-1250 kW	IP 23	IC01	IM 1001 (B3) - welded frame
■ Sf 315-450	160-1000 kW	IP 54	IC611	IM 1001 (B3) - welded frame
■ SVf 355-450	160-1000 kW	IP 54	IC511	IM 3011 (V1) - welded frame
■ Sf 355-710-E	250-2100 kW	IP 55	IC611	IM 1001 (B3) - welded frame
■ Sfw 560-710	1250-3150 kW	IP 55	IC81W	IM 1102 (B3) - welded frame
■ Sh 355-560	160-1800 kW	IP 55	IC411	IM 1001 (B3) - cast iron frame
■ SVh 355-560	160-1800 kW	IP 55	IC411	IM 3011 (V1) - welded frame

**Open drip-proof IP23 motors "SCf" range** can operate only indoors where ambient atmosphere does not include dust or other mechanical or chemical contamination. Air dustiness should not be greater than 2 mg/m<sup>3</sup>.

**Totally enclosed IP54/55 motors** can operate in contaminated atmosphere. However air dustiness cannot be greater than 10 mg/m<sup>3</sup>. Allowable contamination cannot be of aggressive type, such as acid or lye fumes. Ambient atmosphere should also be free from explosive mixtures and fine dust particles. When operated outdoors, motors should be roofed to protect from direct rain, snow and sunshine.

**"Sf-E", "Sfw" and "Sh" range motors** can be applied in power industry and are suitable for operational conditions of thermal power station internal drives (such as pumps, ventilators, coal mills, belt conveyors, etc.) and for all drives of especially hard starting condition. Motors can be applied in fast Automatic Stand-by Switching systems. They could be restarted at 100% residual voltage and full phase opposition. The motor life is circa 5000 startings or 10000 reversals.

All the motors are manufactured in Quality Assurance System consistent with ISO 9001.

ISO9001

The motors covered by the present catalogue comply with the regulations and standards effective in other countries, consistent with IEC standards.

IEC

## DESCRIPTION OF THE CATALOGUE VERSION

Voltage	6000 V $\pm$ 5%; 50 Hz $\pm$ 2%
Duty type	S1 continuous
Insulation class	F (VPI Vacuum Pressure Impregnation)
Ambient temperature	from -20 C° up to +40 C° - "SCf", "Sf", "SVf", "Sf", "Sh", "SVh" range
Altitude	from 0 C° up to +40 C° - "Sfw" range
Noise level	up to 1000 m above sea level
Degree of protection	acc. to IEC 60034-9
Degree of protection of terminal boxes	according to table above
Method of cooling	IP 55
Mounting arrangement	air - according to table above
Starting	IM1001 (B3)
Number of stator terminals	IM1102 (B3) - Sfw 710
Terminal box position	IM3011 (V1) - "SVf" and "SVh" range
Direction of rotation	direct on line
Vibration limit	3 - "SCf", "Sf", "SVf", "Sf", "Sh", "SVh" range
Thermal winding protection	3+3 - Sfw 710
Thermal bearing protection	RH or LH - facing from DE
Paint finish	TOP - "Sh" series
	both (CW/CCW)
	one (CW or CCW) -
	for 2 and 4-poles motors - "Sh" and "Sfw" range
	N v<2,8 mm/s RMS
	R v<1,8 mm/s RMS - for "Sh" range
	6 x Pt100 (2 pcs/phase)
	2 x Pt100 (1 pcs/bearing node)
	blue - RAL 5010

*As part of our development program, we reserve the right to alter or amend any of the specifications without giving prior notice.*

## DESCRIPTION OF THE CUSTOMISED VERSION

- Supply voltage within the range: 1000 - 11000 V
- Mains frequency 60 Hz
- Bearing vibration sensors installed
- Terminal box placed on left side of frame
- For special environmental conditions (marine, dry tropical TA, wet tropical TH)
- Space heaters installed
- Bearing vibration sensors installed

## TOLERANCES

In conformity with IEC 60034-1 the tolerances are:

- Efficiency ( $\eta$ ):  $-0,1(1-\eta)$
- Power factor ( $\cos\varphi$ ):  $-1/6(1-\cos\varphi)$
- Slip :  $\pm 20\%$
- Starting current:  $+20\%$
- Starting torque:  $-15\%$  up to  $+25\%$
- Breakdown torque:  $-10\%$ ,
- Rotor of inertia:  $\pm 10\%$

## BEARINGS

Type of motor	Number of poles	DE side	NDE side
SCf 315 XK; X; Y	2	6317 C3	6317 C3
	4	6320 MC3	NU320 C3
	6	6320 C3	NU320 C3
SCf 355 X; Y	2	6318 C3	6318 C3
	4-8	NU222 EM1 + 6222 MC3	NU 222 EM1
	4-8	NU226 EM1 + 6226 MC3	NU 226 EM1
SCf 450 X; Y	4-12	NU226 EM1 + 6226 MC3	NU 226 EM1
Sf 315 XK; X; Y	2	6317 C3	6317 P636S
	4	6320 MC3	NU320 C3
	6	6320 C3	NU320 C3
Sf 355 X; Y	2	6318 C3	6318 C3
	4-8	NU222 EM1 + 6222 MC3	NU222 EM1
	4-8	NU226 EM1 + 6226 MC3	NU226 EM1
Sf 450 X; Y	4-12	NU226 EM1 + 6226 MC3	NU226 EM1
Sfw 560	2	EFZLB 9-100	EFZLQ 9-100
Sf 560 X; Y	4-8	NU226 EM1 + 6226 MC3	NU226 EM1
Sf 560 H	4-6	NU232 EM1 + 6232 MC3	NU226 EM1
Sfw 710	2	EFZLK 11-140	EFZLQ 11-125
Sfw 710	4	NU234EM1+ 6234MC3	NU232 EM1
Sf 710 X; Y	8-12	NU238 EM1+ 6238 MC3	NU232 EM1
SVf 355 X; Y	4-8	6322 MC3	7322 BTVP
SVf 400 X; Y	4-8	6324 MC3	7322 BTVP
SVf 450 X; Y	4-12	6326 MC3	7322 BTVP
Sh 355	2	6217 C3	6217 C3
	4-8	6322 MC3	6322 MC3
SVh 355	4-8	6322 MC3	6322 MC3
Sh 400	2	6218 M4/C3	6218 M4/C3
	4-8	6324 MC3	6322 MC3
SVh 400	4-8	6324 MC3	7322 BTVP
Sh 450	2	EFNLB 9-90 or 6318 MC3	EFNLQ 9-90 or 6318 MC3
	4-10	6324 MC3	NU222 EM1
SVh 450	4-10	6324 MC3	7322 BTVP
Sh 500	2	EFNLB 11-100	EFNLQ 9-100
	4-12	NU226 EM1 + 6226 MC3	NU226 EM1
SVh 500	4-12	6326 MC3	QJ326N2MPA
Sh 560	2	EFZLK 11-125	EFZLQ 11-100
	4-10	NU230 EM1 + 6230 MC3	NU226 EM1
SVh 560	4-10	6232 MC3	7332 BMP

**Mounting Arrangement IM 1001 (B3)**  
**Open Drip-Proof Motors IP 23**  
**Cooling System IC 01**  
**Voltage 6000 V, 50 Hz**

Item	Type of motor	Rated output		Rated Speed	Rated torque	Efficiency	Power factor	Full load current	Starting torque	Starting current	Breakdown torque	Moment of inertia	Weight (IMB3)
		$P_N$ [kW]	[HP]										
<b>2p=2      <math>n_s=3000</math> rpm</b>													
1.	SCf 315 XK2	200	270	2964	645	93,7	0,9	22,8	0,8	4,8	2,2	1,9	1210
2.	SCf 315 X2	250	340	2964	806	94,4	0,9	28,3	0,9	5,0	2,2	2,1	1300
3.	SCf 315 Y2	315	430	2963	1016	94,8	0,9	35,5	0,9	5,0	2,2	2,3	1420
4.	SCf 355 Y2B	400	540	2966	1289	95,0	0,91	44,5	0,8	5,0	2,2	3,6	1760
5.	SCf 355 Y2	500	680	2966	1611	95,3	0,91	55,5	0,8	5,1	2,2	4,1	1900
<b>2p=4      <math>n_s=1500</math> rpm</b>													
6.	SCf 315 XK4	200	270	1480	1291	93,5	0,86	24,0	0,9	4,5	2,1	4,2	1280
7.	SCf 315 X4	250	340	1480	1614	94,0	0,88	29,2	1,0	4,6	2,1	4,8	1390
8.	SCf 315 Y4	315	430	1480	2034	94,7	0,88	36,5	1,0	4,8	2,1	5,5	1560
9.	SCf 355 X4	400	540	1480	2582	94,9	0,87	46,6	0,9	4,4	1,9	7,6	1750
10.	SCf 355 Y4	500	680	1482	3224	95,3	0,87	58,1	1,1	4,8	2,0	9,2	2040
11.	SCf 400 X4	630	850	1483	4059	95,3	0,9	70,7	0,8	4,8	2,0	16,7	2890
12.	SCf 400 Y4	800	1080	1485	5147	95,6	0,9	89,5	0,9	5,5	2,2	20,0	3160
13.	SCf 450 X4	1000	1350	1486	6430	95,9	0,9	111,0	0,8	5,0	2,1	32,4	3590
14.	SCf 450 Y4	1250	1680	1485	8039	96,0	0,9	139,0	0,8	5,0	2,1	35,9	3750
<b>2p=6      <math>n_s=1000</math> rpm</b>													
15.	SCf 315 X6	200	270	986	1938	93,7	0,84	24,5	1,0	4,5	2,1	6,8	1420
16.	SCf 315 Y6	250	340	986	2423	94,2	0,84	30,5	1,1	4,6	2,0	7,8	1600
17.	SCf 355 X6	315	430	986	3053	94,2	0,84	38,3	1,1	4,5	1,9	10,3	1840
18.	SCf 355 Y6	400	540	987	3872	94,7	0,84	48,4	1,2	4,7	2,0	12,8	2130
19.	SCf 400 X6	500	680	987	4840	94,8	0,85	59,7	1,0	4,6	1,9	21,5	2890
20.	SCf 400 Y6	630	850	987	6099	95,2	0,85	74,9	1,1	4,9	2,0	25,1	3180
21.	SCf 450 X6	800	1080	990	7721	95,1	0,88	92,0	0,8	4,7	1,9	51,0	3600
22.	SCf 450 Y6	1000	1350	989	9661	95,3	0,88	115,0	0,8	4,5	1,9	56,2	4130
<b>2p=8      <math>n_s=750</math> rpm</b>													
23.	SCf 355 X8	200	270	739	2586	93,3	0,8	25,8	1,0	4,5	2,0	10,3	1840
24.	SCf 355 Y8	250	340	739	3232	93,9	0,8	32,0	1,1	4,7	2,0	12,8	2130
25.	SCf 400 X8	315	430	740	4067	93,9	0,83	38,9	0,9	4,7	2,1	22,9	2790
26.	SCf 400 Y8	400	540	740	5165	94,1	0,83	49,3	0,9	4,6	2,0	25,9	2970
27.	SCf 450 X8	500	680	741	6447	94,3	0,84	60,7	0,9	4,8	2,0	48,8	3370
28.	SCf 450 Y8	630	850	742	8113	94,6	0,84	76,3	1,0	4,9	2,0	55,9	3630
29.	SCf 450 Y8B	800	1080	741	10310	94,9	0,84	96,7	1,0	4,7	1,8	64,1	3960
<b>2p=10      <math>n_s=600</math> rpm</b>													
30.	SCf 450 X10A	200	270	593	3223	93,0	0,81	25,5	0,9	5,4	2,4	40,2	2790
31.	SCf 450 X10B	250	340	593	4028	93,3	0,81	31,8	1,0	5,4	2,3	43,2	2910
32.	SCf 450 X10C	315	430	592	5084	93,6	0,82	39,5	1,0	5,1	2,2	47,8	3090
33.	SCf 450 X10D	400	540	591	6467	93,8	0,82	50,0	0,9	4,7	2,0	53,6	3310
34.	SCf 450 Y10	500	680	591	8084	94,1	0,83	61,6	0,9	4,8	2,0	63,6	3600
35.	SCf 450 Y10B	630	850	591	11162.	95,1	0,82	77,8	0,8	4,5	1,8	77,3	3850
<b>2p=12      <math>n_s=500</math> rpm</b>													
26.	SCf 450 X12A	200	270	493	3874	93,6	0,79	25,9	0,8	5,0	2,5	45,9	2980
37.	SCf 450 X12B	250	340	491	4865	92,8	0,79	32,8	0,9	4,9	2,3	50,1	3130
38.	SCf 450 X12C	315	430	490	6143	92,9	0,79	41,3	0,9	4,5	2,1	54,0	3280
39.	SCf 450 Y12	400	540	490	7800	93,1	0,8	51,7	0,9	4,4	2,0	63,9	3580
40.	SCf 450 Y12B	500	680	492	9705	94,8	0,82	62,0	0,7	4,8	2,0	74,0	3950

## Mounting Arrangement IM 1001 (B3)

Totally Enclosed Motors IP54/55

Cooling System IC 611

Voltage 6000 V, 50 Hz

Item	Type of motor	Rated output		Rated speed $n_N$ [rpm]	Rated torque $M_N$ [Nm]	Efficiency $\eta_N$ [%]	Power factor $\cos \varphi_N$ [-]	Full load current $I_N$ [A]	Starting torque $M_s/M_N$ [-]	Starting current $I_s/I_N$ [-]	Breakdown torque $M_{max}/M_N$ [-]	Moment of inertia J [kgm <sup>2</sup> ]	Weight (IMB3) m [kg]
		$P_N$ [kW]	[HP]										
<b>2p=2      <math>n_s=3000</math> rpm</b>													
41.	Sf 315 XK2	160	220	2972	514	92,9	0,9	18,4	1,0	6,0	2,7	2,0	1360
42.	Sf 315 X2	200	270	2972	643	93,6	0,9	22,8	1,1	6,3	2,7	2,2	1450
43.	Sf 315 Y2	250	340	2971	804	94,2	0,9	28,4	1,1	6,3	2,7	2,4	1540
44.	Sf 355 Y2B	315	430	2971	1013	93,6	0,91	35,6	1,0	6,0	2,7	3,7	1930
45.	Sf 355 Y2	400	540	2974	1285	95,1	0,91	44,5	1,0	6,4	2,7	4,2	2100
<b>2p=4      <math>n_s=1500</math> rpm</b>													
46.	Sf 315 XK4	160	220	1485	1029	93,5	0,86	19,1	1,1	5,2	2,2	4,2	1400
47.	Sf 315 X4	200	270	1485	1288	94,2	0,86	23,8	1,4	6,0	2,6	4,8	1510
48.	Sf 315 Y4	250	340	1485	1609	94,3	0,87	29,3	1,3	6,0	2,8	5,5	1680
49.	Sf 355 X4	315	430	1485	2027	94,0	0,87	37,1	1,3	5,7	2,3	7,8	2060
50.	Sf 355 Y4	400	540	1486	2572	94,9	0,87	46,6	1,4	6,0	2,5	9,4	2310
51.	Sf 400 X4	500	680	1487	3213	95,1	0,9	56,2	1,0	6,0	2,5	17,0	3140
52.	Sf 400 Y4	630	850	1486	4051	95,4	0,9	70,6	0,9	5,8	2,4	18,5	3240
53.	Sf 450 X4	800	1080	1489	5134	95,7	0,9	89,4	1,0	6,2	2,6	32,8	4080
54.	Sf 450 Y4	1000	1350	1489	6417	95,9	0,9	111	1,0	6,2	2,6	36,3	4240
<b>2p=6      <math>n_s=1000</math> rpm</b>													
55.	Sf 315 X6	160	220	989	1546	93,6	0,83	19,8	1,1	5,5	2,5	6,8	1540
56.	Sf 315 Y6	200	270	989	1932	94,0	0,82	24,7	1,3	5,6	2,5	7,8	1720
57.	Sf 355 X6	250	340	989	2415	94,0	0,83	30,8	1,4	5,6	2,4	10,6	2080
58.	Sf 355 Y6	315	430	990	3040	94,6	0,83	38,6	1,5	6,0	2,4	13,1	2400
59.	Sf 400 X6	400	540	990	3861	94,8	0,84	48,3	1,2	5,8	2,3	21,8	3100
60.	Sf 400 Y6	500	680	990	4826	95,1	0,84	60,2	1,3	6,0	2,5	25,9	3390
61.	Sf 450 X6	630	850	992	6068	95,0	0,89	71,7	1,0	6,0	2,4	51,6	4100
62.	Sf 450 Y6	800	1080	991	7713	95,3	0,89	90,8	1,0	5,6	2,3	56,7	4310
<b>2p=8      <math>n_s=750</math> rpm</b>													
63.	Sf 355 X8	160	220	741	2063	93,2	0,78	21,2	1,3	5,5	2,5	10,6	2080
64.	Sf 355 Y8	200	270	741	2579	93,8	0,78	26,3	1,4	5,7	2,5	13,1	2400
65.	Sf 400 X8	250	340	742	3219	93,6	0,81	31,7	1,1	5,8	2,6	23,4	2980
66.	Sf 400 Y8	315	430	742	4056	93,9	0,81	39,9	1,1	5,7	2,5	26,0	3160
67.	Sf 450 X8	400	540	743	5144	94,4	0,83	49,1	1,1	6,0	2,5	49,6	3870
68.	Sf 450 Y8	500	680	744	6421	94,7	0,83	61,2	1,3	6,1	2,5	56,7	4120
69.	Sf 450 Y8B	650	880	742	8366	95,1	0,85	77,4	1,3	5,6	2,1	65,0	4450
<b>2p=10      <math>n_s=600</math> rpm</b>													
70.	Sf 450 X10A	160	220	595	2569	93,2	0,77	21,5	1,1	6,0	2,9	40,2	3320
71.	Sf 450 X10B	200	270	594	3217	94,5	0,79	25,8	1,1	5,9	2,8	43,2	3430
72.	Sf 450 X10C	250	340	594	4021	94,6	0,8	31,8	1,2	6,0	2,7	48,9	3600
73.	Sf 450 X10D	315	430	593	5076	93,8	0,8	40,4	1,1	5,9	2,5	54,5	3800
74.	Sf 450 Y10	400	540	593	6445	94,1	0,81	50,5	1,1	6,0	2,5	64,4	4090
75.	Sf 450 Y10B	500	680	593	8052	94,8	0,82	63,5	1,0	5,6	2,3	78,3	4300
<b>2p=12      <math>n_s=500</math> rpm</b>													
76.	Sf 450 X12A	160	220	495	3087	94,0	0,79	20,7	0,9	5,7	2,6	41,3	3490
77.	Sf 450 X12B	200	270	494	3866	94,0	0,79	25,9	0,9	5,5	2,6	47,0	3630
78.	Sf 450 X12C	250	340	494	4833	94,3	0,79	32,3	0,9	5,7	2,6	51,0	3720
79.	Sf 450 Y12	315	430	494	6089	94,5	0,81	39,6	0,9	5,7	2,6	61,5	3980
80.	Sf 450 Y12B	400	540	494	7779	95,0	0,81	50,0	0,9	5,8	2,6	73,5	4300



**Mounting Arrangement IM 3011 (V1)**  
**Totally Enclosed Motors IP 54/55**  
**Cooling System IC 511**  
**Voltage 6000 V, 50 Hz**

Item	Type of motor	Rated output		Rated Speed $n_N$ [rpm]	Rated torque $M_N$ [Nm]	Efficiency $\eta_N$ [%]	Power factor $\cos \varphi_N$ [-]	Full load current $I_N$ [A]	Starting torque $M_s/M_N$ [-]	Starting current $I_s/I_N$ [-]	Breakdown torque $M_{max}/M_N$ [-]	Moment of inertia $J$ [kgm <sup>2</sup> ]	Weight (IMB3) $m$ [kg]
		$P_N$ [kW]	[HP]										
<b>2p=4      <math>n_s=1500</math> rpm</b>													
81.	SVf 355 X4A	160	220	1487	1027	93,0	0,86	19,2	1,1	5,8	2,7	5,2	1620
82.	SVf 355 X4B	200	270	1486	1285	93,6	0,87	23,6	1,1	5,6	2,5	5,8	1700
83.	SVf 355 X4C	250	340	1487	1605	94,4	0,88	28,9	1,3	6,0	2,6	6,8	1810
84.	SVf 355 X4	315	430	1485	2025	94,4	0,87	36,9	1,1	5,6	2,4	7,8	2060
85.	SVf 355 Y4	400	540	1486	2570	94,9	0,87	46,6	1,4	6,0	2,5	9,4	2210
86.	SVf 400 X4	500	680	1487	3211	95,1	0,9	56,2	1,0	6,0	2,5	17,0	3140
87.	SVf 400 Y4	630	850	1486	4048	95,4	0,9	70,6	0,9	5,8	2,4	18,5	3240
88.	SVf 450 X4	800	1080	1489	5130	95,7	0,9	89,4	1,0	6,2	2,6	32,8	4080
89.	SVf 450 Y4	1000	1350	1489	6413	95,9	0,9	111,0	1,0	6,2	2,6	36,3	4240
<b>2p=6      <math>n_s=1000</math> rpm</b>													
90.	SVf 355 X6A	160	220	990	1543	93,6	0,83	19,8	1,2	5,3	2,4	7,4	1710
91.	SVf 355 X6B	200	270	991	1927	94,2	0,83	24,6	1,3	5,8	2,4	8,6	1830
92.	SVf 355 X6	250	340	989	2414	94,0	0,83	30,8	1,4	5,6	2,4	10,6	2080
93.	SVf 355 Y6	315	430	990	3038	94,6	0,83	38,6	1,5	6,0	2,4	13,1	2400
94.	SVf 400 X6	400	540	990	3858	94,8	0,84	48,3	1,2	5,8	2,3	21,8	3100
95.	SVf 400 Y6	500	680	990	4823	95,1	0,84	60,2	1,3	6,0	2,5	25,9	3390
96.	SVf 450 X6	630	850	992	6065	95,0	0,89	71,7	1,0	6,0	2,4	51,6	4100
97.	SVf 450 Y6	800	1080	991	7709	95,3	0,89	90,8	1,0	5,6	2,5	56,7	4310
<b>2p=8      <math>n_s=750</math> rpm</b>													
98.	SVf 355 X8	160	220	741	2062	93,2	0,78	21,2	1,3	5,5	2,5	10,6	2080
99.	SVf 355 Y8	200	270	741	2577	93,8	0,78	26,3	1,4	5,7	2,5	13,1	2400
100.	SVf 400 X8	250	340	742	3217	93,6	0,81	31,7	1,1	5,8	2,6	23,4	2980
101.	SVf 400 Y8	315	430	742	4054	93,9	0,81	39,9	1,1	5,7	2,5	26,0	3160
102.	SVf 450 X8	400	540	743	5141	94,4	0,83	49,1	1,1	6,0	2,5	49,6	3870
103.	SVf 450 Y8	500	680	744	6418	94,7	0,83	61,2	1,3	6,1	2,5	56,7	4120
104.	SVf 450 Y8B	650	880	742	8365	95,1	0,85	77,4	1,3	5,6	2,1	65,0	4450
<b>2p=10      <math>n_s=600</math> rpm</b>													
105.	SVf 450X10A	160	220	595	2568	93,2	0,77	21,5	1,1	6,0	2,9	40,2	3320
106.	SVf 450 X10B	200	270	594	3215	94,5	0,79	25,8	1,1	5,9	2,8	43,2	3430
107.	SVf 450 X10C	250	340	594	4019	94,6	0,8	31,8	1,2	6,0	2,7	48,9	3600
108.	SVf 450 X10D	315	430	593	5072	93,8	0,8	40,4	1,1	5,9	2,5	54,5	3800
109.	SVf 450 Y10	400	540	593	6441	94,1	0,81	50,5	1,1	6,0	2,5	64,4	4090
110.	SVf 450 Y10B	500	680	593	8052	94,8	0,82	63,5	1,0	5,6	2,3	78,3	4300
<b>2p=12      <math>n_s=500</math> rpm</b>													
111.	SVf 450 X12A	160	220	495	3086	94,0	0,79	20,7	0,9	5,7	2,6	41,3	3490
112.	SVf 450 X12B	200	270	494	3866	94,0	0,79	25,9	0,9	5,5	2,6	47,0	3630
113.	SVf 450 X12C	250	340	494	4833	94,3	0,79	32,3	0,9	5,7	2,6	51,0	3720
114.	SVf 450 Y12	315	430	494	6089	94,5	0,81	39,6	0,9	5,7	2,6	61,5	3980
115.	SVf 450 Y12B	400	540	494	7732	95,0	0,81	50,0	0,9	5,8	2,6	73,5	4300

**Mounting Arrangement IM 1001 (B3)**

Totally Enclosed IP 55

Cooling System IC 611, IC 81W

Voltage 6000 V, 50 Hz

**Motors for Power Engineering Industry**

Item	Type of motor	Rated output		Rated speed $n_N$ [rpm]	Rated torque $M_N$ [Nm]	Efficiency $\eta_N$ [%]	Power factor $\cos \varphi_N$ [-]	Full load current $I_N$ [A]	Starting torque $M_r/M_N$ [-]	Starting current $I_r/I_N$ [-]	Breakdown torque $M_{max}/M_N$ [-]	Moment of inertia J [kgm <sup>2</sup> ]	Weight (IMB3) m [kg]
		$P_N$ [kW]	[HP]										
<b>2p=2      n<sub>s</sub>=3000 rpm</b>													
116.	Sf 355 Y2-E	250	340	2973	802	93,8	0,9	28,5	1,1	5,3	2,6	4,9	1970
117.	Sf 355 Y2-E	280	380	2973	899	94,5	0,89	31,9	0,9	5,3	2,7	4,9	1970
118.	Sf 355 Y2-E	315	430	2974	1012	94,4	0,89	36,2	0,9	5,7	2,5	4,9	1970
119.	Sfw 560 J2A-G	1250	1680	2985	3999	96,2	0,9	139,0	0,5	6,0	2,1	29,0	5850
120.	Sfw 560J2B-G	1400	1880	2988	4475	96,9	0,9	155,0	0,5	6,2	2,4	29,0	5850
121.	Sfw 710-2A	2250	3040	2986	7196	96,6	0,9	249,0	0,4	4,8	1,9	79,0	8400
122.	Sfw 710-2B	2500	3380	2988	7990	96,7	0,9	276,0	0,5	5,5	2,1	91,0	8680
123.	Sfw 710-2C	2800	3780	2989	8946	97,0	0,9	309,0	0,6	6,2	2,3	110,0	9500
124.	Sfw 710-2D	3150	4260	2987	10071	97,1	0,9	347,0	0,45	5,5	2,1	110,0	9500
<b>2p=4      n<sub>s</sub>=1500 rpm</b>													
125.	Sf 355 X4A-E	200	270	1484	1287	93,5	0,86	23,9	1,9	6,0	2,4	7,3	2100
126.	Sf 355 X4B-E	250	340	1484	1609	94,2	0,86	29,7	1,9	5,9	2,4	8,3	2220
127.	Sf 355 Y4-E	315	430	1486	2024	93,7	0,86	37,7	1,8	6,0	2,5	9,4	2430
128.	Sf 400 X4-E	400	540	1478	2585	94,3	0,89	45,9	1,2	5,0	2,1	17,0	3250
129.	Sf 400 Y4-E	500	680	1479	3229	94,7	0,89	57,1	1,25	5,2	2,1	20,6	3510
130.	Sf 450 X4-E	650	880	1484	4183	94,8	0,86	76,7	1,7	6,0	2,3	32,8	4230
131.	Sf 450 Y4-E	850	1140	1483	5474	95,2	0,86	100,0	1,7	5,7	2,1	36,3	4540
132.	Sf 560 X4-E	1000	1350	1491	6405	95,9	0,91	110,0	0,8	6,5	2,5	60,0	5980
133.	Sf 560 Y4-E	1250	1680	1491	8006	96,2	0,91	138,0	0,8	6,5	2,5	68,5	6400
134.	Sf 560 Y4B-E	1400	1880	1490	8973	96,2	0,91	154,0	0,7	6,0	2,2	68,5	6400
135.	Sf 560 H4-E	1600	2140	1490	10255	96,4	0,89	180,0	0,7	5,9	2,1	78,0	7100
136.	Sf 560 H4B-E	1800	2400	1490	11537	96,6	0,9	200,0	0,8	6,0	2,2	85,5	7750
137.	Sf 560 H4C-E	2000	2680	1492	12802	97,0	0,91	218,0	0,7	6,3	2,3	105,0	8100
138.	Sfw 710-4A*	2200	2992	1495	14054	97,3	0,90	242,0	0,5	6,1	2,3	135,0	8755
139.	Sfw 710-4B*	2500	3400	1495	15970	97,5	0,90	274,0	0,6	6,5	2,4	151,0	9300
140.	Sfw 710-4C*	2800	3807	1495	17886	97,5	0,90	307,0	0,6	6,5	2,4	160,0	9555
141.	Sfw 710-4D*	3150	4283	1495	20122	97,6	0,90	345,0	0,6	6,5	2,4	171,0	9980
<b>2p=6      n<sub>s</sub>=1000 rpm</b>													
142.	Sf 315 Y6-E	160	220	991	1542	94,8	0,83	19,8	2,2	5,9	2,1	7,3	1660
143.	Sf 355 X6-E	200	270	985	1939	93,7	0,82	25,0	2	5,8	2,4	11,5	2240
144.	Sf 355 Y6-E	250	340	985	2424	93,9	0,82	31,2	2	5,8	2,4	13,1	2450
145.	Sf 400 X6-E	315	430	982	3063	93,8	0,81	39,9	1,8	5,2	2,3	21,8	3150
146.	Sf 400 Y6-E	400	540	982	3890	94,2	0,81	50,5	1,85	5,3	2,3	25,9	3540
147.	Sf 450 X6-E	500	680	987	4838	94,8	0,86	59,0	1,7	6,0	2,3	51,6	4270
148.	Sf 450 Y6-E	630	850	986	6102	95,0	0,86	74,2	1,6	5,6	2,1	56,7	4560
149.	Sf 560 X6-E	800	1080	993	7694	95,5	0,88	92,0	0,9	6,5	2,4	86,0	6020
150.	Sf 560 Y6-E	1000	1350	993	9617	95,9	0,88	114,0	0,9	6,5	2,4	98,0	6440
151.	Sf 560 H6-E	1250	1680	994	12021	96,7	0,89	140,0	0,7	6,2	1,9	136,0	7880
152.	Sf 560 H6-E	1400	1880	995	13437	96,8	0,88	158,0	0,8	6,2	2,0	136,0	7880
153.	Sf 560 H6B-E	1500	2000	995	14397	97,0	0,89	167,0	0,9	6,6	2,2	153,0	8330
154.	Sf 560 H6C-E	1700	2280	996	16300	97,1	0,89	189,0	0,6	6,3	2,1	153,0	8330

\* - dimensional drawing of Sfw 710-4 A,B,C,D type motors available on request.

Mounting Arrangement IM 1001 (B3)

Totally Enclosed IP 55

Cooling System IC 611

Voltage 6000 V, 50 Hz

Motors for Power Engineering Industry

Item	Type of motor	Rated output		Rated Speed $n_N$ [rpm]	Rated torque $M_N$ [Nm]	Efficiency $\eta_N$ [%]	Power factor $\cos \varphi_N$ [-]	Full load current $I_N$ [A]	Starting torque $M_r/M_N$ [-]	Starting current $I_r/I_N$ [-]	Breakdown torque $M_{max}/M_N$ [-]	Moment of inertia J [kgm <sup>2</sup> ]	Weight (IMB3) m [kg]
		[kW]	[HP]										
<b>2p=8 <math>n_s=750</math> rpm</b>													
155.	Sf 355 Y8-EA	160	220	744	2054	94,4	0,73	22,3	2,3	6,7	2,7	13,1	2430
156.	Sf 355 Y8-EA	200	270	742	2574	93,8	0,76	27,0	2,2	5,9	2,3	13,1	2430
157.	Sf 450 X8A-E	200	270	740	2582	93,0	0,78	26,5	1,9	5,7	2,2	39	3640
158.	Sf 450 X8B-E	250	340	739	3232	93,5	0,79	32,6	1,9	5,5	2,1	44	3800
159.	Sf 450 X8C-E	315	430	739	4073	93,9	0,79	40,9	1,9	5,4	2,1	50	4020
160.	Sf 450 Y8-E	400	540	739	5172	94,3	0,79	51,7	1,9	5,4	2,1	57	4370
161.	Sf 560 X8-E	500	680	744	6418	95,1	0,86	58,8	0,9	5,8	2,2	89	5650
162.	Sf 560 Y8-E	630	850	744	8086	95,4	0,86	73,9	1,0	6,0	2,2	97	6090
163.	Sf 560 H8-E	800	1080	746	10240	96,5	0,86	92,9	0,8	6,1	2,2	134	7200
164.	Sf 560 H8B-E	1000	1350	746	12801	96,8	0,86	115,0	0,8	5,6	2,0	168	8000
165.	Sf 560 H8C-E	1250	1680	745	16023	96,8	0,86	145,0	0,7	5,1	1,9	182	8260
166.	Sf 710 X8	1400	1880	746	17922	96,7	0,87	160,0	0,55	5,7	2,0	224	10180
167.	Sf 710 X8B	1600	2140	746	20482	96,7	0,87	183,0	0,6	6,0	2,1	224	10180
168.	Sf 710 Y8	1800	2400	746	23043	96,8	0,87	206,0	0,6	5,9	2,0	251	10660
169.	Sf 710 Y8B	2000	2680	746	25603	96,9	0,87	228,0	0,6	6,0	2,2	288	11270
170.	Sf 710 Y8C	2100	2815	746	26883	97,0	0,87	240,0	0,5	5,6	1,9	305	11300
<b>2p=10 <math>n_s=600</math> rpm</b>													
171.	Sf 560 X10-E	560	760	595	8988	95,8	0,82	68,5	1,1	6,0	2,2	136	5900
172.	Sf 560 Y10-E	630	850	595	10112	95,9	0,82	77,0	1,2	6,4	2,3	156	6240
173.	Sf 560 H10-E	800	1080	596	12819	96,0	0,83	96,7	1,1	6,0	2,2	180	6620
174.	Sf 710 X10	1000	1350	595	16050	96,1	0,84	119,0	0,8	5,1	1,9	247	9400
175.	Sf 710 Y10	1250	1680	596	20029	96,2	0,84	149,0	1,0	6,0	2,1	316	10400
176.	Sf 710 Y10B	1400	1880	595	22471	96,2	0,84	167,0	1,0	6,0	2,1	344	10700
<b>2p=12 <math>n_s=500</math> rpm</b>													
177.	Sf 560 X12-E	500	680	495	9646	95,6	0,82	61,5	0,8	5,8	2,2	136	5800
178.	Sf 560 X12-E	560	760	494	10826	95,4	0,83	68,1	0,75	5,2	2,0	136	5800
179.	Sf 560 Y12-E	630	850	494	12179	95,5	0,83	76,6	0,8	5,3	2,0	160	6200
180.	Sf 560 H12-E	800	1080	495	15434	95,7	0,83	97,0	0,8	5,5	2,0	215	7680
181.	Sf 710 X12	1000	1350	496	19254	95,9	0,78	129,0	0,6	5,5	1,9	290	10500
182.	Sf 710 Y12	1250	1680	497	23058	96,2	0,80	150,0	0,6	5,3	1,8	316	11070
183.	Sf 710 Y12B	1350	1810	497	25940	96,0	0,78	174,0	0,7	5,7	1,9	344	11130
184.	Sf 710 Y12C	1450	1944	497	27862	96,4	0,81	179,0	0,6	5,5	2,0	344	11130

**Mounting Arrangement IM 1001 (B3)**  
 Totally Enclosed IP 55  
 Cooling System IC 411  
 Voltage 6000 V, 50 Hz

**High Efficiency Motors**

Item	Type of motor	Rated output		Rated speed	Rated torque	Efficiency	Power factor	Full load current	Starting torque	Starting current	Breakdown torque	Moment of inertia	Weight (IMB3)
		$P_N$ [kW]	[HP]										
<b>2p=2      <math>n_s=3000</math> rpm</b>													
185.	Sh 355 H2A	160	220	2978	513	94,8	0,89	18,3	1,2	6,6	2,7	2,3	1820
186.	Sh 355 H2B	200	270	2978	641	95,3	0,9	22,3	1,3	6,7	2,7	2,5	1870
187.	Sh 355 H2C	250	340	2978	802	95,7	0,9	27,9	1,4	6,7	2,6	2,8	1950
188.	Sh 355 H2D	315	430	2978	1010	96,0	0,91	34,7	1,5	6,7	2,6	3,2	2060
189.	Sh 400 H2A	355	480	2983	1137	95,7	0,89	40,1	1,2	6,1	2,2	4,1	2600
190.	Sh 400 H2B	400	540	2981	1281	95,9	0,89	45,1	1,3	6,3	2,3	4,5	2600
191.	Sh 400 H2C	450	610	2983	1441	96,1	0,89	50,7	1,3	6,4	2,3	4,7	2670
192.	Sh 400 H2D	500	680	2983	1601	96,3	0,89	56,1	1,3	6,6	2,3	5,0	2790
193.	Sh 400 H2E	560	760	2984	1792	96,5	0,89	62,7	1,5	7,0	2,4	5,8	3010
194.	Sh 450 H2B	630	850	2988	2014	97,0	0,9	69,4	1,0	7,1	2,8	12,4	4190
195.	Sh 450 H2C	710	960	2987	2270	96,7	0,89	79,0	0,8	6,9	2,8	13,1	4100
196.	Sh 450 H2D	800	1080	2989	2556	97,3	0,9	88,0	0,9	7,2	2,8	14,0	4250
197.	Sh 500 H2A	900	1210	2989	2876	97,2	0,89	100,0	0,5	5,5	2,1	21,9	5800
198.	Sh 500 H2B	1000	1350	2988	3196	97,3	0,89	111,0	0,5	5,6	2,1	24,0	6090
199.	Sh 500 H2C	1120	1510	2988	3580	97,3	0,89	125,0	0,6	5,9	2,1	28,4	6350
200.	Sh 500 H2D	1250	1680	2989	3994	97,5	0,89	139,0	0,6	5,9	2,2	30,0	6700
201.	Sh 560 H2A	1400	1880	2990	4472	97,5	0,89	155,0	0,5	6,1	2,0	44,4	7650
202.	Sh 560 H2B	1600	2140	2991	5109	97,5	0,89	178,0	0,6	6,5	2,2	49,6	8000
203.	Sh 560 H2C	1800	2400	2992	5745	97,6	0,89	200,0	0,7	7,0	2,3	56,8	8550
<b>2p=4      <math>n_s=1500</math> rpm</b>													
204.	Sh 355 H4A	160	220	1490	1026	95,6	0,82	19,6	1,2	6,4	2,6	4,3	1950
205.	Sh 355 H4B	200	270	1488	1284	95,8	0,84	23,9	1,2	6,0	2,4	5,0	2060
206.	Sh 355 H4C	250	340	1487	1606	96,1	0,84	29,8	1,2	6,0	2,4	5,4	2160
207.	Sh 355 H4D	315	430	1486	2024	96,2	0,85	37,1	1,2	5,8	2,2	6,1	2280
208.	Sh 400 H4A	355	480	1489	2277	96,1	0,83	42,8	1,1	6,0	2,4	7,4	2700
209.	Sh 400 H4B	400	540	1488	2567	96,2	0,84	47,7	1,1	5,8	2,2	8,2	2920
210.	Sh 400 H4C	450	610	1489	2886	96,5	0,84	53,5	1,2	6,4	2,5	9,2	3110
211.	Sh 400 H4D	500	680	1489	3207	96,6	0,84	59,3	1,3	6,6	2,5	9,8	3040
212.	Sh 400 H4E	560	760	1489	3592	96,7	0,84	66,3	1,4	6,6	2,6	10,5	3350
213.	Sh 450 H4A	630	850	1493	4030	97,0	0,89	70,5	0,9	6,4	2,4	23,2	3980
214.	Sh 450 H4B	710	960	1494	4538	96,8	0,89	79,3	0,9	6,9	2,5	24,4	4330
215.	Sh 450 H4C	800	1080	1493	5114	97,2	0,89	89,0	0,9	6,7	2,4	26,3	4300
216.	Sh 500 H4A	900	1210	1494	5753	97,1	0,88	102,0	0,6	5,9	2,2	48,0	5840
217.	Sh 500 H4B	1000	1350	1494	6392	97,4	0,88	112,0	0,9	6,3	2,3	52,7	6180
218.	Sh 500 H4C	1120	1510	1494	7159	97,5	0,88	126,0	0,7	6,5	2,3	54,0	6400
219.	Sh 500 H4D	1250	1680	1495	7985	97,5	0,88	140,0	0,7	6,7	2,4	60,2	6700
220.	Sh 500 H4E	1400	1880	1494	8943	97,5	0,89	155,0	0,9	7,0	2,4	64,2	7260
221.	Sh 560 H4A	1600	2140	1495	10221	97,6	0,89	178,0	0,6	5,5	2,0	102,0	8300
222.	Sh 560 H4B	1800	2400	1495	11498	97,6	0,89	200,0	0,6	5,7	2,0	109,0	8600

**Mounting Arrangement IM 1001 (B3)**  
 Totally Enclosed IP 55  
 Cooling System IC 411  
 Voltage 6000 V, 50 Hz

**High Efficiency Motors**

Item	Type of motor	Rated output		Rated Speed	Rated torque	Efficiency	Power factor	Full load current	Starting torque	Starting current	Breakdown torque	Moment of inertia	Weight (IMB3)
		$P_N$ [kW]	[HP]										
<b>2p=6      <math>n_s=1000</math> rpm</b>													
223.	Sh 355 H6A	160	220	992	1540	94,7	0,79	20,6	1,4	6,4	2,6	6,9	2030
224.	Sh 355 H6B	200	270	991	1927	94,9	0,8	25,3	1,4	6,2	2,4	8,2	2140
225.	Sh 355 H6C	250	340	991	2409	95,2	0,8	31,6	1,4	6,2	2,4	9,4	2280
226.	Sh 400 H6A	315	430	993	3029	95,6	0,8	39,6	1,2	6,2	2,3	12,5	2930
227.	Sh 400 H6B	355	480	993	3414	95,8	0,8	44,6	1,2	6,1	2,2	13,8	3075
228.	Sh 400 H6C	400	540	993	3847	95,9	0,81	49,6	1,2	6,2	2,2	14,7	3240
229.	Sh 450 H6A	450	610	992	4332	96,0	0,84	53,7	0,8	5,2	2,2	25,3	3800
230.	Sh 450 H6B	500	680	992	4814	96,2	0,84	60,0	0,9	5,4	2,3	27,9	4050
231.	Sh 450 H6C	560	760	994	5380	96,3	0,84	66,7	1,0	6,4	2,5	33,6	4250
232.	Sh 450 H6D	630	850	994	6053	96,5	0,84	74,8	1,0	6,5	2,6	38,3	4650
233.	Sh 500 H6A	710	960	996	6808	96,7	0,84	84,1	1,0	6,8	2,5	57,5	6130
234.	Sh 500 H6B	800	1080	995	7678	96,8	0,84	94,8	1,0	6,7	2,4	61,0	6280
235.	Sh 500 H6C	900	1210	995	8638	97,0	0,85	105,0	1,0	6,5	2,3	67,4	6540
236.	Sh 500 H6D	1000	1350	995	9598	97,0	0,85	117,0	0,9	6,2	2,2	72,6	6830
237.	Sh 500 H6E	1120	1510	995	10750	97,0	0,86	129,0	0,9	6,1	2,1	82,5	7220
238.	Sh 560 H6A	1250	1680	996	11985	97,4	0,86	144,0	0,7	6,2	2,2	118,0	8000
239.	Sh 560 H6B	1400	1880	996	13424	97,5	0,86	161,0	0,75	6,4	2,2	131,0	8440
240.	Sh 560 H6C	1600	2140	996	15341	97,6	0,86	184,0	0,8	6,5	2,2	148,0	9210
<b>2p=8      <math>n_s=750</math> rpm</b>													
241.	Sh 355 H8A	160	220	740	2065	93,8	0,74	22,1	1,0	4,3	1,8	7,3	2140
242.	Sh 355 H8B	180	240	740	2323	94,0	0,74	24,8	1,0	4,2	1,8	8,3	2190
243.	Sh 355 H8C	200	270	740	2581	94,2	0,74	27,6	1,0	4,2	1,7	9,5	2265
244.	Sh 400 H8A	250	340	744	3209	94,8	0,74	34,3	1,1	5,2	2,4	19,1	3150
245.	Sh 400 H8B	315	430	744	4043	95,2	0,74	43,0	1,1	5,0	2,4	22,0	3360
246.	Sh 450 H8A	355	480	744	4557	95,9	0,78	46,0	1,0	5,6	2,3	32,4	4100
247.	Sh 450 H8B	400	540	744	5134	96,0	0,78	51,4	1,0	5,6	2,2	35,7	4250
248.	Sh 450 H8C	450	610	744	5776	96,1	0,78	57,8	1,0	5,7	2,3	38,6	4560
249.	Sh 450 H8D	500	680	744	6418	96,2	0,78	64,2	1,0	5,8	2,3	45,0	4750
250.	Sh 500 H8A	560	760	746	7169	96,3	0,81	69,1	1,0	6,4	2,5	62,3	5560
251.	Sh 500 H8B	630	850	746	8065	96,4	0,81	77,7	1,0	6,5	2,5	70,2	5890
252.	Sh 500 H8C	710	960	746	9089	96,5	0,8	88,5	1,0	6,5	2,5	78,2	6280
253.	Sh 500 H8D	800	1080	746	10241	96,3	0,81	98,7	1,0	6,9	2,5	89,5	6830
254.	Sh 560 H8A	900	1210	746	11521	96,6	0,8	112,0	0,9	6,7	2,4	118,0	7200
255.	Sh 560 H8B	1000	1350	746	12802	96,9	0,8	124,0	0,9	6,8	2,4	131,0	7880
<b>2p=10      <math>n_s=600</math> rpm</b>													
256.	Sh 450 H10A	280	380	594	4502	95,1	0,81	35,0	0,9	5,6	2,4	43,8	3890
257.	Sh 450 H10B	315	430	594	5064	95,3	0,81	39,3	1,0	5,9	2,5	48,5	4060
258.	Sh 450 H10C	355	480	594	5707	95,4	0,81	44,2	1,0	6,0	2,6	55,0	4300
259.	Sh 500 H10A	400	540	592	6453	95,2	0,83	48,8	1,1	4,9	2	71,6	5400
260.	Sh 500 H10B	450	610	592	7259	95,2	0,83	54,9	1,1	4,8	1,9	82,9	5690
261.	Sh 500 H10C	500	680	592	8066	95,4	0,83	60,7	1,2	5,1	1,9	94,5	5960
262.	Sh 500 H10D	560	760	593	9018	95,6	0,83	67,9	1,2	5,3	2,0	109,0	6290
263.	Sh 500 H10E	630	850	594	10128	95,8	0,83	76,3	1,5	6,3	2,4	116,0	6490
264.	Sh 560 H10A	710	960	593	11434	96,2	0,83	85,7	1,2	6,2	2,2	153,0	7200
265.	Sh 560 H10B	800	1080	593	12884	96,3	0,83	96,4	1,0	5,8	2,0	169,0	7600
<b>2p=12      <math>n_s=500</math> rpm</b>													
266.	Sh 500 H12B	315	430	495	6077	95,4	0,82	38,8	1,0	6,1	2,4	85,0	5700
267.	Sh 500 H12C	355	480	496	6835	95,5	0,82	43,7	1,0	6,1	2,4	95,5	5940
268.	Sh 500 H12D	400	540	496	7702	95,6	0,81	49,8	1,1	6,4	2,5	109,0	6230
269.	Sh 500 H12E	450	610	495	8682	95,4	0,81	56,1	1,1	6,0	2,3	116,0	6400



**OPEN DRIP-PROOF MOTORS - IP 23  
MOUNTING ARRANGEMENT - IM B3**

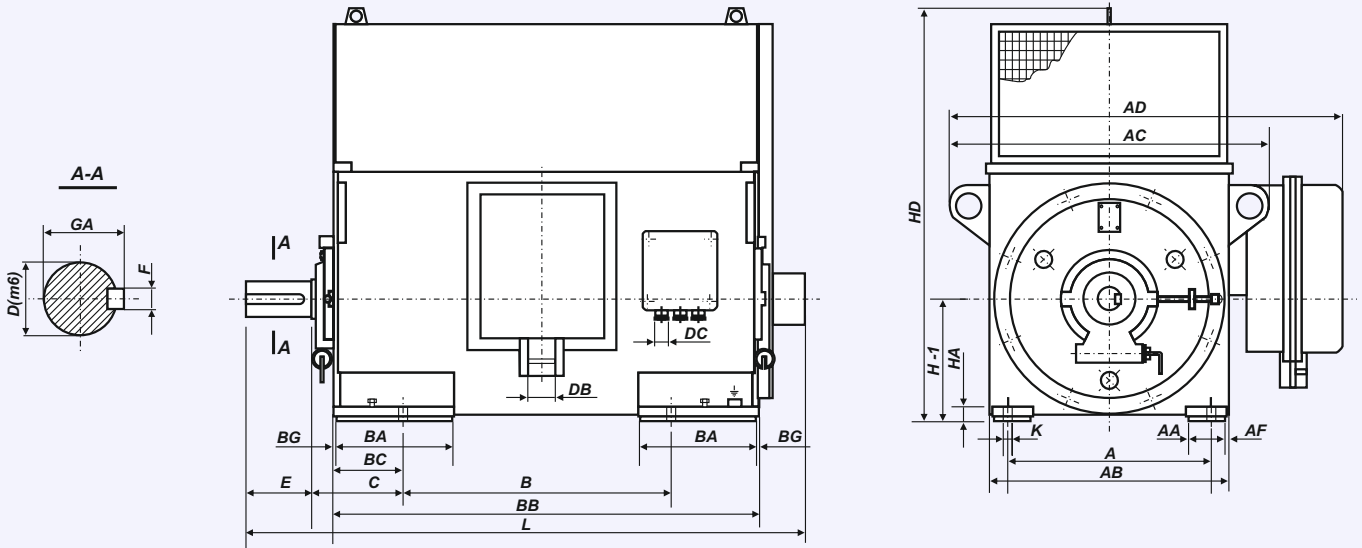
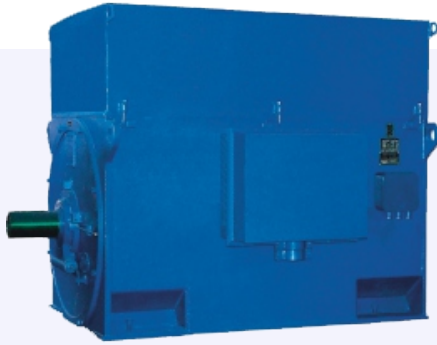

Motor type	Poles	A	AA	AB	AC	AD	AF	B	BA	BB	BC	BG	C	D	DB	DC	E	F	GA	GD	H	HA	HD	K	L
SCf315XK;X	2	560	100	660	882	1110	11	710	320	1170	181	10	224	70	55	15	140	20	74,5	12	315	31	1020	28	1392
SCf315Y	2	560	100	660	882	1110	11	800	320	1170	181	10	224	70	55	15	140	20	74,5	12	315	31	1020	28	1392
SCf315X	4-6	560	100	660	882	1110	11	710	320	1170	181	10	224	90	55	15	170	25	95,0	14	315	31	1020	28	1536
SCf315Y	4-6	560	100	660	882	1110	11	800	320	1250	181	10	224	90	55	15	170	25	95,0	14	315	31	1020	28	1626
SCf355Y;YB	2	630	100	750	972	1195	10	900	320	1273	203	10	254	75	55	15	140	20	79,5	12	355	28	1295	28	1546
SCf355X	4-8	630	100	750	972	1195	10	800	320	1273	203	10	254	100	55	15	210	28	106,0	16	355	28	1295	28	1710
SCf355Y	4-8	630	100	750	972	1195	10	900	320	1373	203	10	254	100	55	15	210	28	106,0	16	355	28	1295	28	1810
SCf400X	4-8	710	130	866	1092	1306	10	900	490	1540	203	10	280	110	55	15	210	28	116,0	16	400	32	1301	35	2011
SCf400Y	4-8	710	130	866	1092	1306	10	1000	490	1540	203	10	280	110	55	15	210	28	116,0	16	400	32	1301	35	2011
SCf450X	4-12	800	130	980	1198	1415	10	1000	390	1540	238	10	315	120	55	15	210	32	127,0	18	450	32	1450	35	2010
SCf450Y	4-12	800	130	980	1198	1415	10	1120	390	1540	238	10	315	120	55	15	210	32	127,0	18	450	32	1450	35	2010

**TOTALLY ENCLOSED MOTORS - IP 54  
MOUNTING ARRANGEMENT - IM B3**

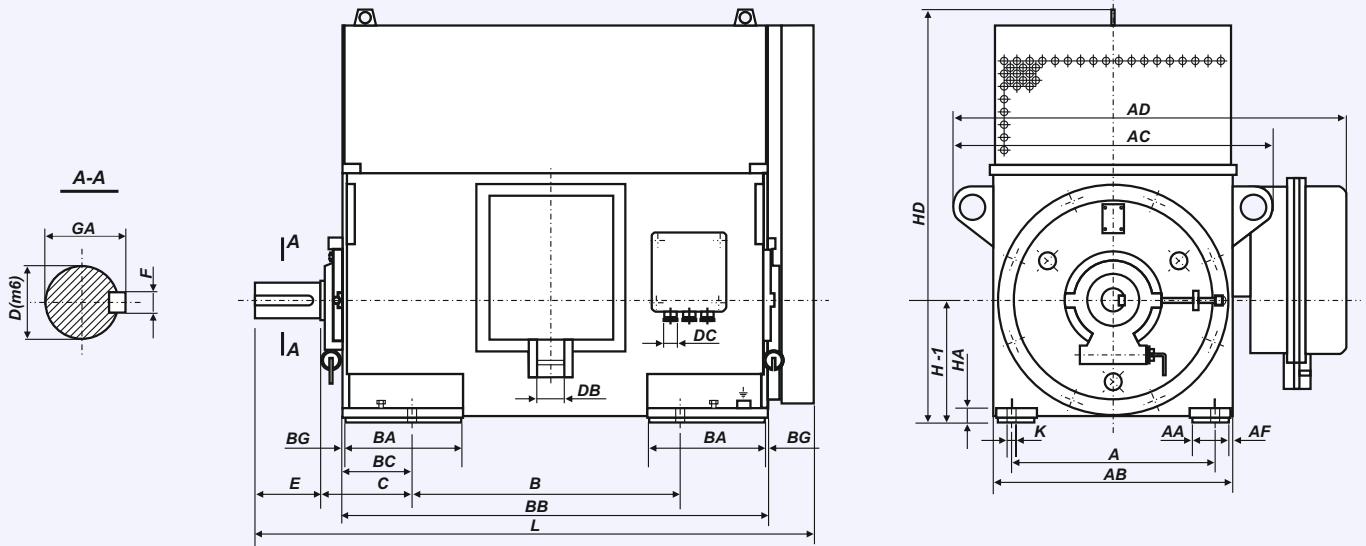

Motor type	Poles	A	AA	AB	AC	AD	AF	B	BA	BB	BC	BG	C	D	DB	DC	E	F	GA	GD	H	HA	HD	K	L
Sf 315 XK;X	2	560	100	660	882	1110	11	710	320	1170	181	10	224	70	55	15	140	20	74,5	12	315	31	1085	28	1730
Sf 315 Y	2	560	100	660	882	1110	11	800	320	1170	181	10	224	70	55	15	140	20	74,5	12	315	31	1085	28	1730
Sf 315 X	4-6	560	100	660	882	1110	11	710	320	1170	181	10	224	90	55	15	170	25	95,0	14	315	31	1085	28	1610
Sf 315 Y	4-6	560	100	660	882	1110	11	800	320	1250	181	10	224	90	55	15	170	25	95,0	14	315	31	1085	28	1700
Sf 355 Y;YB	2	630	100	750	972	1195	10	900	320	1273	203	10	254	75	55	15	140	20	79,5	12	355	28	1303	28	1930
Sf 355 X	4-8	630	100	750	972	1195	10	800	320	1273	203	10	254	100	55	15	210	28	106,0	16	355	28	1303	28	1860
Sf 355 Y	4-8	630	100	750	972	1195	10	900	320	1373	203	10	254	100	55	15	210	28	106,0	16	355	28	1303	28	1960
Sf 400 X	4-8	710	130	866	1092	1306	10	900	490	1540	203	10	280	110	55	15	210	28	116,0	16	400	32	1400	35	2136
Sf 400 Y	4-8	710	130	866	1092	1306	10	1000	490	1540	203	10	280	110	55	15	210	28	116,0	16	400	32	1400	35	2136
Sf 450 X	4-12	800	130	980	1198	1415	10	1000	390	1540	238	10	315	120	55	15	210	32	127,0	18	450	32	1603	35	2146
Sf 450 Y	4-12	800	130	980	1198	1415	10	1120	390	1540	238	10	315	120	55	15	210	32	127,0	18	450	32	1603	35	2146

**TOTALLY ENCLOSED MOTORS - IP 54  
MOUNTING ARRANGEMENT - IM V1**

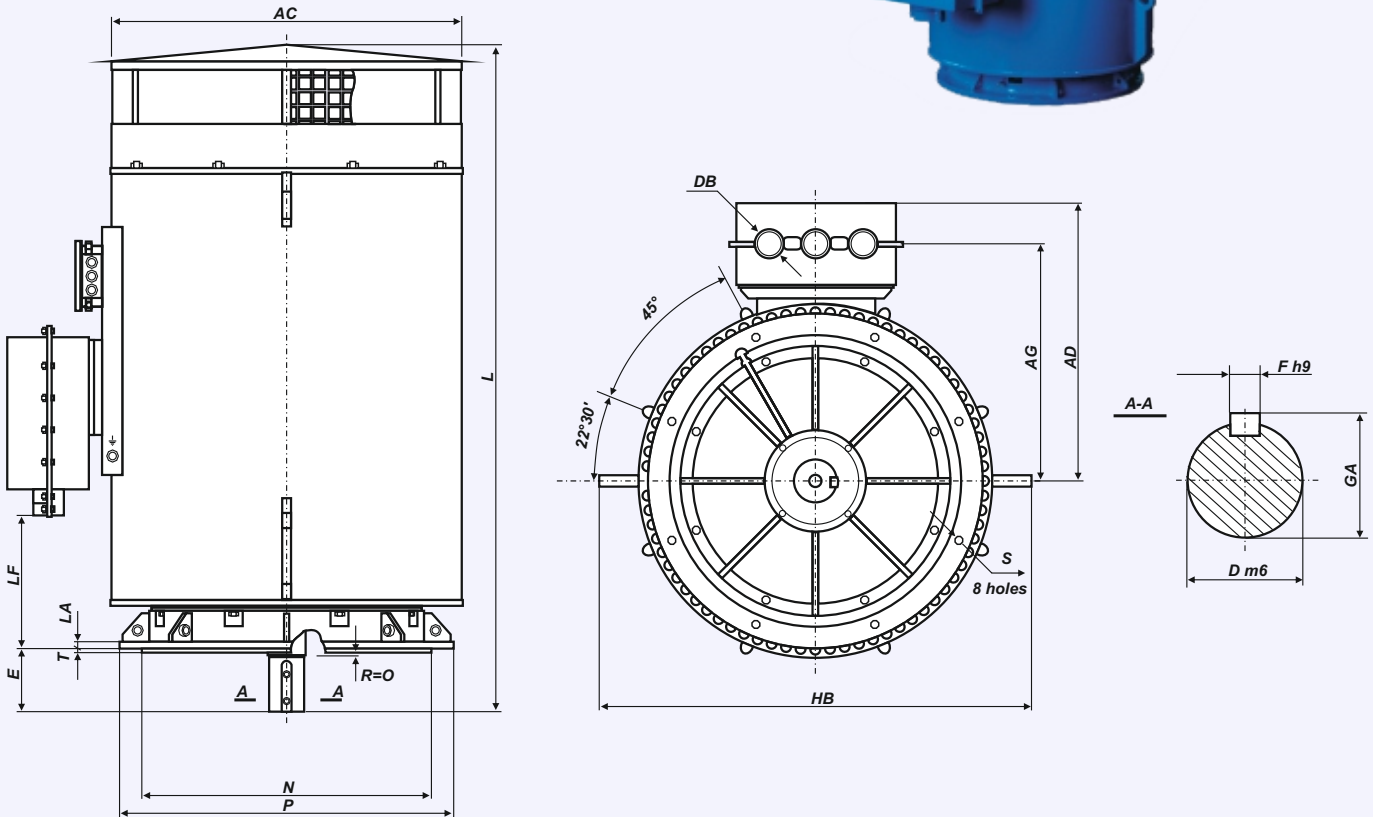

Motor type	AC	AD	AG	D	DB	E	F	GA	HB	L	LA	LF	M	N	P	R	S	T
SVf 355 XA, XB, XC	966	870	729	100	55	210	28	106	1228	1766	24	353	740	680	800	0	22	6
SVf 355 X, Y	966	870	729	100	55	210	28	106	1228	1966	24	392	740	680	800	0	22	6
SVf 400 X, Y	1096	933	793	110	55	210	28	116	1354	2212	30	424	940	880	1000	0	25	6
SVf 450 X, Y	1226	1000	860	120	55	210	32	127	1484	2295	30	500	1080	1000	1150	0	28	6

**TOTALLY ENCLOSED MOTORS - IP 55  
MOUNTING ARRANGEMENT - IM B3**

**MOTORS FOR POWER ENGINEERING INDUSTRY**

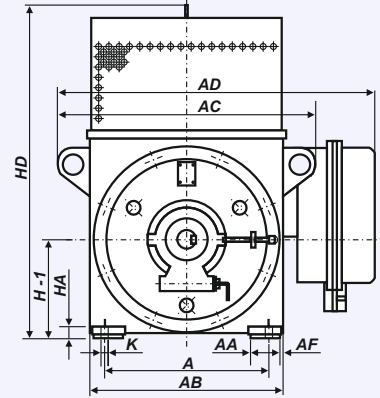
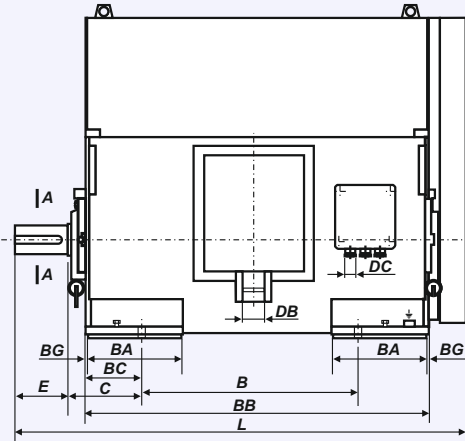
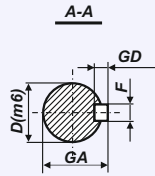

Motor type	A	AA	AB	AC	AD	AF	B	BA	BB	BC	BG	C	D	DB	DC	E	F	GA	GD	H	HA	HD	K	L
Sf 355 Y2-E	630	100	750	972	1195	10	900	320	1373	203	10	254	75	55	15	140	20	79,5	12	355	28	1305	28	1930
Sf 355 X-E	630	100	750	972	1195	10	800	320	1273	203	10	254	100	55	15	210	28	106,0	16	355	28	1303	28	1860
Sf 355 Y-E	630	100	750	972	1195	10	900	320	1373	203	10	254	100	55	15	210	28	106,0	16	355	28	1303	28	1960
Sf 400 X-E	710	130	866	1092	1306	10	900	490	1540	203	10	280	110	55	15	210	28	116,0	16	400	32	1400	35	2136
Sf 400 Y-E	710	130	866	1092	1306	10	1000	490	1540	203	10	280	110	55	15	210	28	116,0	16	400	32	1400	35	2136
Sf 450 X-E	800	130	980	1198	1415	10	1000	390	1540	238	10	315	120	55	15	210	32	127,0	18	450	32	1603	35	2146
Sf 450 Y-E	800	130	980	1198	1415	10	1120	390	1540	238	10	315	120	55	15	210	32	127,0	18	450	32	1603	35	2146
Sf 560 X-E	1000	160	1144	1388	1592	10	1120	325	1540	202	10	280	120	55	15	210	32	127,0	18	560	30	1833	42	2151
Sf 560 Y-E	1000	160	1144	1388	1592	10	1120	325	1540	202	10	280	120	55	15	210	32	127,0	18	560	30	1833	42	2151
Sf 560 YB-E	1000	160	1144	1388	1592	10	1120	325	1540	202	10	280	125	55	15	210	32	132,0	18	560	30	1833	42	2151
Sf 560 H-E	1000	160	1144	1388	1592	10	1400	370	1868	234	10	315	140	55	15	250	36	148,0	20	560	30	1833	42	2520
Sf 560 HBC-E	1000	160	1144	1388	1592	10	1400	370	1868	234	10	315	140	55	15	250	36	148,0	20	560	30	1833	42	2520
Sf 710 X	1250	200	1420	1596	1829	10	1250	500	1835	268	10	450	180	55	15	250	45	190,0	20	710	35	2300	42	2690
Sf 710 Y	1250	200	1420	1596	1829	10	1250	500	1835	268	10	450	180	55	15	250	45	190,0	25	710	35	2300	42	2690

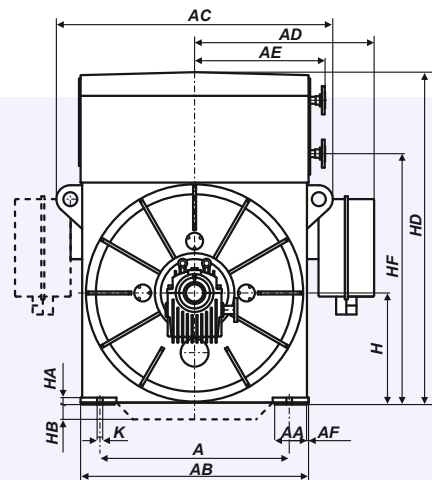
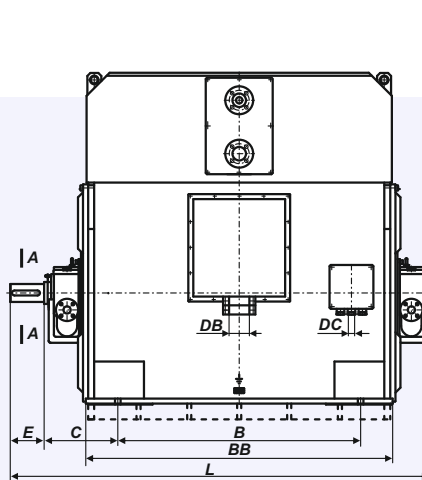
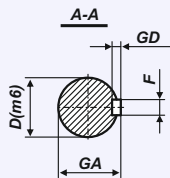

Motor type	A	AA	AB	AC	AD	AE	AF	B	BB	C	D	DB	DC	E	F	GA	GD	H	HA	HB	HD	HF	K	L
Sfw 560	950	160	1144	1390	937	655	10	1250	1540	395	90	55	15	170	25	95	14	560	35	-	1670	1260	28	2105
Sfw 710	1500	270	1760	1480	943	690	10	1600	1960	500	120	2x80	15	150	25	125	14	500	35	90	1905	1309	39	2690

**TOTALLY ENCLOSED MOTORS - IP 55**  
**MOUNTING ARRANGEMENT - IM B3**

**HIGH EFFICIENCY MOTORS**

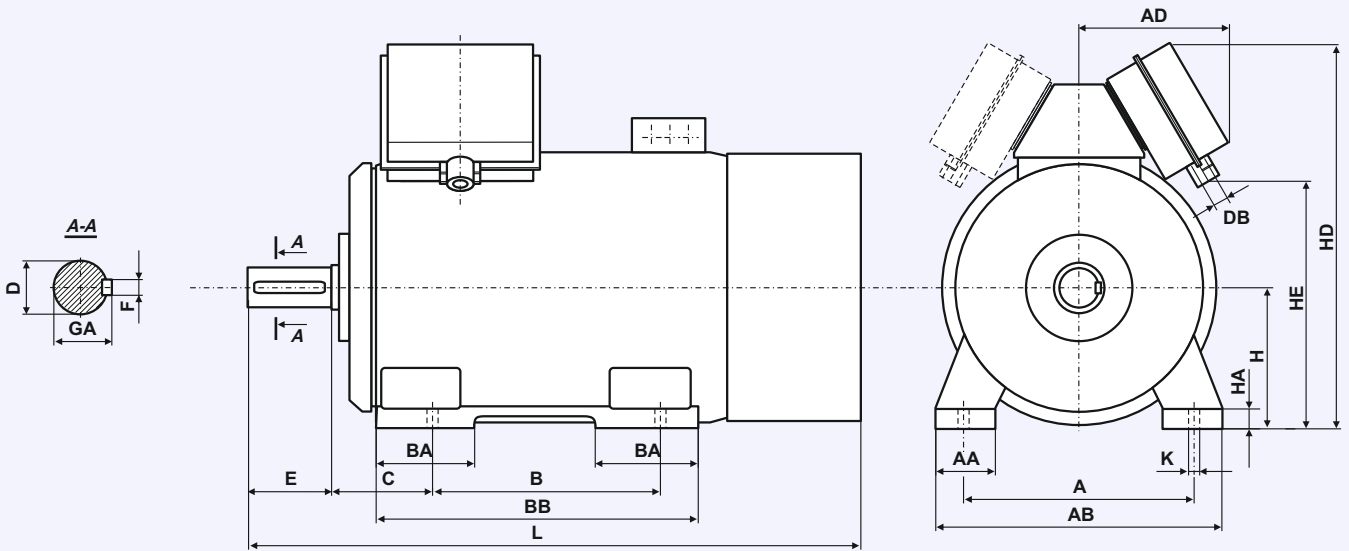

	Motor type	Poles	A	B	C	D	E	F	GA	H	HA	K	AA	AB	AD	BA	BB	HD	HE	L	DB
	Sh 355 H	2	610	900	200	70	140	20	75,0	355	45	28	160	730	565	265	1045	1187	586	1800	55
	Sh 355 H	4-8	610	900	200	100	210	28	106,0	355	45	28	160	730	565	265	1045	1187	586	1870	55
	Sh 400 H	2	686	1000	224	80	170	22	85,5	400	50	35	175	840	565	265	1160	1277	677	1975	55
	Sh 400 H	4-8	686	1000	224	110	210	28	116,0	400	50	35	175	840	565	265	1160	1277	677	1960	55
	Sh 450 H	2	750	1120	450	80	170	22	85,5	450	60	35	205	940	572	340	1320	1356	831	2410	55
	Sh 450 H	4-10	750	1120	254	110	210	28	116,0	450	60	35	205	940	572	340	1320	1356	831	2090	55
	Sh 500 H	2	850	1250	450	90	170	25	95,0	500	70	42	223	1050	567	300	1450	1470	946	2758	55
	Sh 500 H	4-12	850	1250	280	120	210	32	127,0	500	70	42	223	1050	567	300	1450	1470	946	2430	55
	Sh 560 H	2	950	1400	450	110	210	28	116,0	560	70	45	220	1180	570	320	1600	1570	1061	2990	60
	Sh 560 H	4-10	950	1400	315	140	250	36	148,0	560	70	45	220	1180	570	320	1600	1570	1061	2660	60





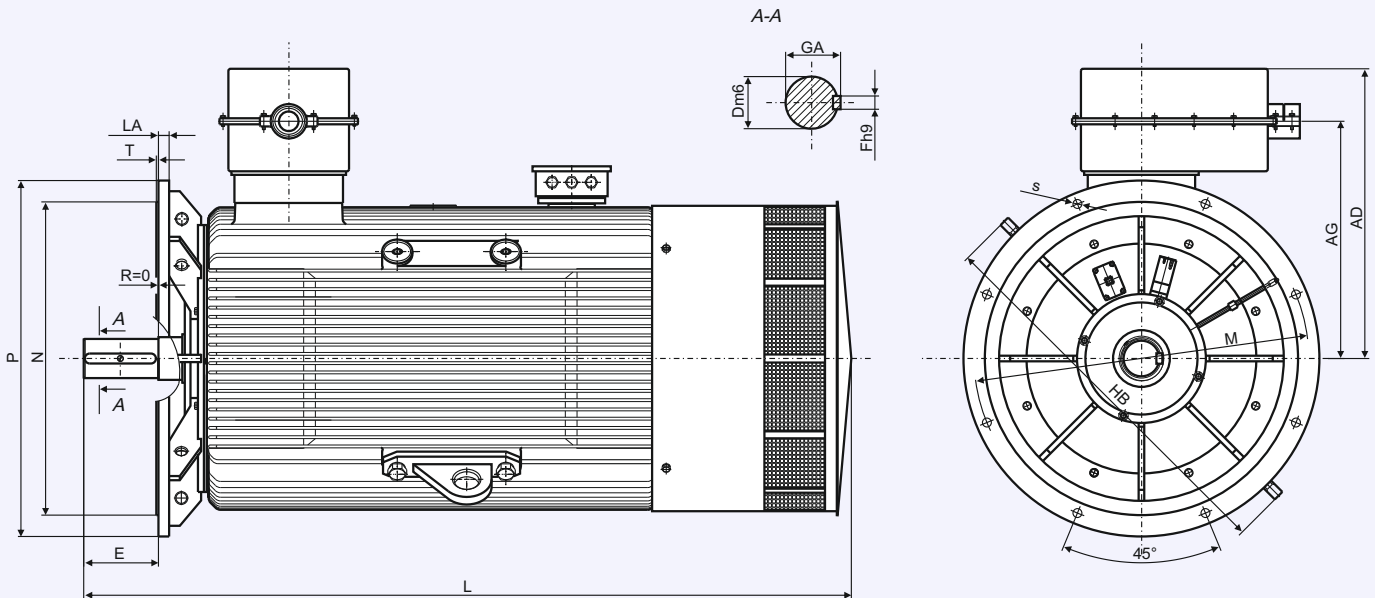

**TOTALLY ENCLOSED MOTORS - IP 55  
MOUNTING ARRANGEMENT - IM 3011 (V1)**

**HIGH EFFICIENCY MOTORS**











Motor type	Poles	AD	AG	D	E	F	GA	L	LA	HB	M	N	P	S	T
SVh 355 H	4-8	767	620	100	210	28	106	1745	24	1050	740	680	800	22	6
SVh 400 H	4-8	814	668	110	210	28	116	2090	37	1150	940	880	1000	23	6
SVh 450 H	4-10	875	735	110	210	28	116	2350	30	1290	1080	1000	1150	28	6
SVh 500 H	4-12	935	796	120	210	32	127	2504	30	1450	1080	1000	1150	28	6
SVh 560 H	4-10	975	836	140	250	36	148	2750	30	---	1320	1250	1400	28	6

## PRODUCT RANGE

GENERAL PURPOSE 3-PHASE INDUCTION MOTORS	Three-phase motors with squirrel-cage rotor series (2)Sg(m), Sh. High efficiency motors series 2SIE, 3SIE and 4SIE (Efficiency classes IE1, IE2, IE3, IE4)	from 0,04kW up to 1400kW	general purpose, pumps, fans, compressors, specific requirements relating to the highest efficiency	
GENERAL PURPOSE 1-PHASE INDUCTION MOTORS	Single-phase motors with squirrel-cage rotor series SEh(R), SEMh(R). - motors with standard starting torque - motors with increased starting torque - motors with high starting torque.	from 0,04kW up to 4kW	general purpose, pumps, fans, compressors, wood machines, machines and devices for food processing, mixers for building	
HIGH VOLTAGE INDUCTION MOTORS	Three-phase squirrel-cage high voltage and high efficiency motors series Sh with cast-iron housing. High voltage motors with module construction (steel/welded housing) series Sf-E and Sfw.	from 160kW up to 3150kW	general industrial use, drives used for own needs of power plants (pumps, fans, coal mills, conveyors)	
BRAKE MOTORS	Three-phase and single-phase brake motors with AC and DC brakes.	from 0,04kW up to 160kW	applied in case of necessity to stop the motor suddenly	
MOTORS WITH FOREIGN COOLING	Three-phase 3-phase induction motors with foreign cooling.	from 0,06kW up to 250kW	drives adapted for speed regulation by frequency converter	
EXPLOSION-PROOF MOTORS	Increased safety motors.  Flame-proof motors.	from 0,06kW up to 22kW  from 0,75kW up to 315kW	adapted for operation in areas endangered by explosion (without methane)  application in an atmosphere where a mixture of explosive gas and vapours may occur	
NEMA MOTORS	Low voltage NEMA motors SIE series (in compliance with the NEMA PREMIUM requirements).	from 1HP up to 250HP	general industrial application, pumps, fans	
TRACTION MOTORS	Traction motors and traction generators.	from 50kW up to 1500kW	various traction vehicles: trams (including low-deck trams), trolleybuses, subway and locomotives	

**PRODUCT RANGE**

SUBMERSIBLE MOTORS	Submersible motors with protection Ip68 Type TMP	from 5,5kW up to 22kW 4 poles standard with 10m connection cable and 6m protection tube  with special shaft (long or short)	PUMP DIRVE Agriculture, liquid manure, biogas, wastewater , sewage plant	
SUBMERSIBLE MOTORS	Special motors desinged and produced from FFD in close coordination with and especially for our customers. From the first idea to the final production.	for example: Submersible motor type: dSKLS (11 and 15kW)  flame proof desing IIG Ex dIIA T4	MIXER Agriculture, liquid manure, biogas, wastewater , sewage plant	
HOLLOW SHAFT MOTORS	Three-phase induction motors with hollow shaft	Frame size: 100 up to 250 Poles: 2, 4, 6, 8, 12  and multiple speed	Suitable for agitators driving with special flange and hollow shaft (without propeller and shaft)	
MARINE MOTORS	Three-phase induction motors	PRS - polish register of shipping GL - German Lloyd ´s LRS - Lloyd ´s Register of shipping DNV - Det Norske Veritas ABS - American Bureau of shipping BV - Bureau Veritas RMRS - Russian Maritime Register of Shipping	Motors designed for use on ships. On deck or under deck. The motors are made to withstand aggressive environments such a salt mist.	
MOTORS FOR INDUSTRIAL FURNANCE AND BLOWERS	Three-phase induction motors	Motors used for air circulation up to 1200°C air temperature	Motors works in drying plants	
COOLING MEDIUM PUMPS	Three phase pumps or Single phase pumps	DKP with 115W EKP with 100W  Dip length: 86mm, 120mm, 170mm, 220mm, 270mm  220-250/380-440V 50/60Hz	Work like centrifugal pumps. These pumps are quite resistant to the pollution of coolants. Manufactured in with 5 different dip length.	
BREAKS	Electromagnetic breaks	H2SP, HPS, 2H2SP, H2SPX H2SP..AT - quiet operation HPS..AT - quiet operation STE, STK - quiet operation 2H2SP..BT - quiet operation, NE - high level of protection NEX - explosion-proof version HZg - alternating current brakes	High standard and high repeatability even with large number of actuations.	
REPAIRS AND SERVICE	Electrical and mechanical repairs of all motor types  Service and testing of all motor types  Also motors from other manufacturers	for example: - new winding - new bearings - new shafts - new PTC, Pt100 or bi-metal switch - new painting (all RAL colors) - new name plate - Motor routine test	We are using only high quality materials for motor repair.	

## NOTICE

## NOTICE



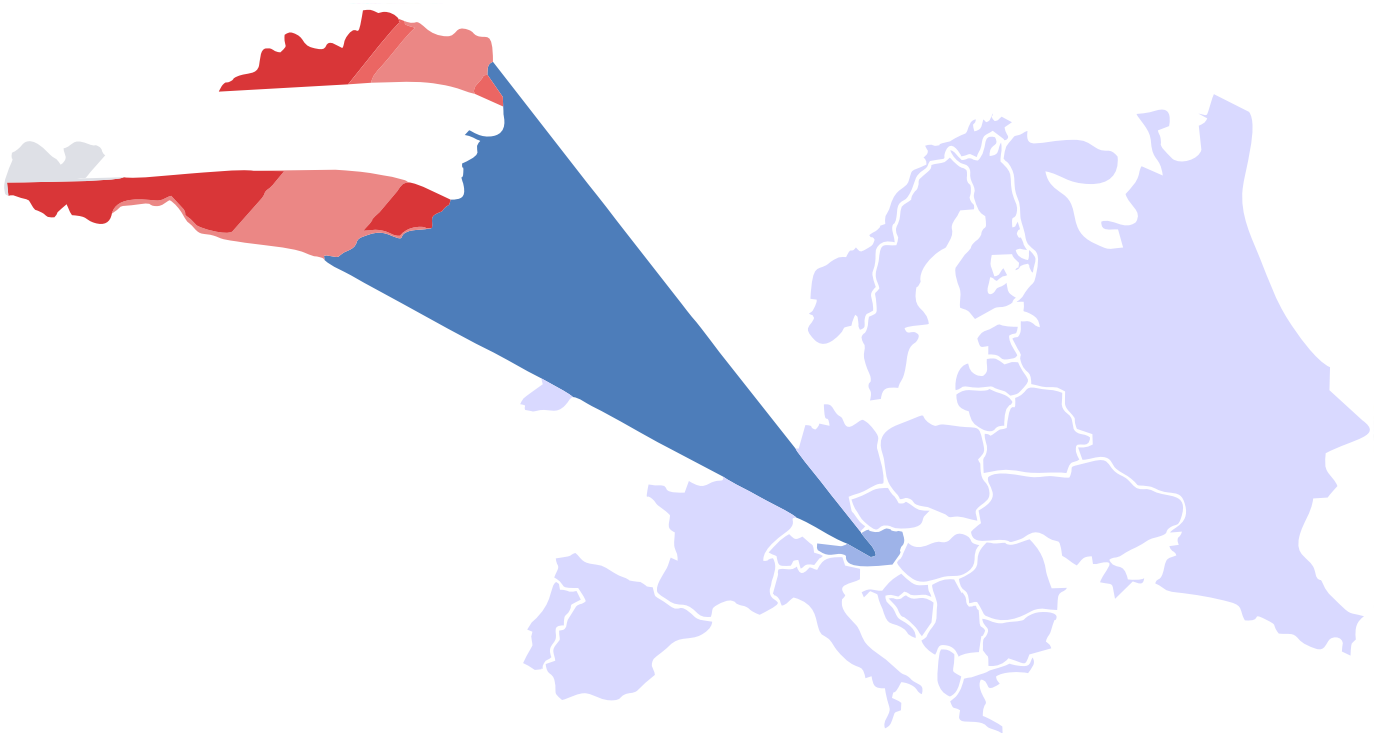

**FFD locadet in the heart  
of Europe, AUSTRIA!**

## **FRANK & DVORAK**

Elektromaschinenbau- und Vertriebsgesellschaft m.b.H. u. Co.KG

**CONTACT ADDRESS:**

Industriestraße 1  
7033 Pöttsching, AUSTRIA  
Phone: +43 2631 8005  
FAX: +43 2631 8005 84  
mail to: [ffd@frank-dvorak.at](mailto:ffd@frank-dvorak.at)  
[www.frank-dvorak.at](http://www.frank-dvorak.at)